

Digital Crane Weight Datasheet

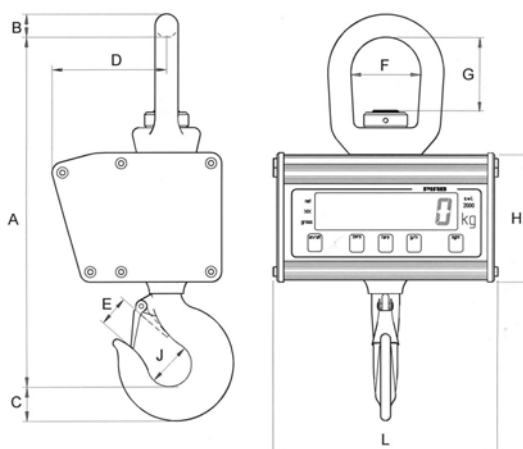

Technical Specification

- The PIAB Digital Crane Weigher is delivered for capacities of 2, 5 and 10 ton metric.
- Accuracy: $\pm 0.1\%$ of max. capacity
- Can temporarily be overloaded by 100% without affecting the accuracy
- Temperature range: -20 C to +60 C
- Tight, conforming to IP 65 according to IEC 529
- Long operating time: 240 hours (55 hours with backlight).
- The Crane Weigher is delivered in a tough plywood case

Type	Capacity (kg)	Resolution (kg)	Weight (kg)	Measurements in mm									
				A	B	C	D	E	F	G	H	J	L
DKV 2	2000	1	5.7	320	21	31	104	28	64	67	119	40	206
DKV 5	5000	2	10.7	414	28	48	104	40	90	84	119	53	206
DKV 10	10000	5	13.1	454	28	56	104	50	90	84	119	67	206